

SERPAC 252

Electronics Enclosures

NOTES:
 1. WHEN MACHINE OR I PLATES MODIFICATIONS ARE REQUIRED, USE THE CENTER OF THE BOX TO DIMENSION.

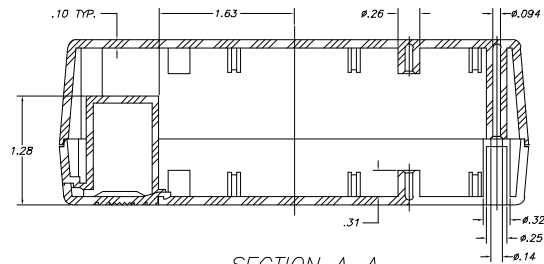
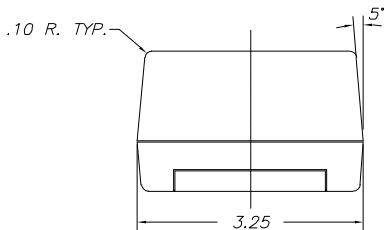
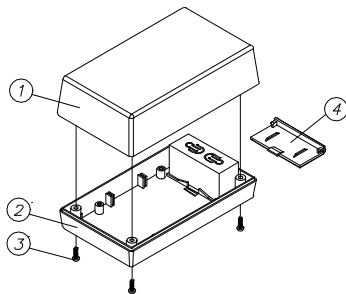
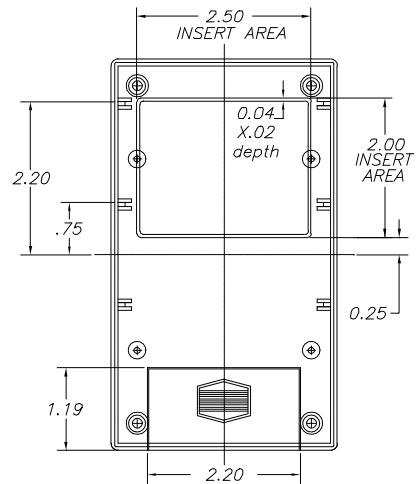
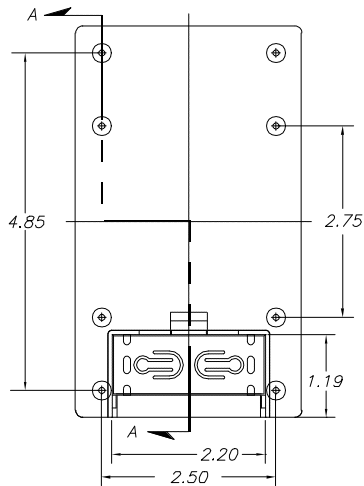
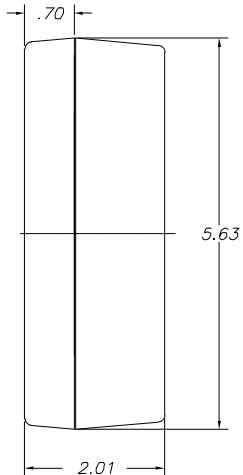

SECTION A-A

10-05-98

ALL DIMENSIONS ± .010

ITEM	PART NO.	DESCRIPTION	ACCESSORIES	
			PART NO.	DESCRIPTION
1	52	PLASTIC TOP		
2	25	PLASTIC BOTTOM		
3	1025	PLASTIC BATTERY COVER	50	FEET
4	6005	SCREWS (4)	359	PROTOTYPE GRID BOARD (HORIZ.)
			459	PROTOTYPE CLAD BOARD (HORIZ.)
			352	PROTOTYPE GRID BOARD (VERT.)
			452	PROTOTYPE CLAD BOARD (VERT.)
			PC	POCKET CLIP